

# Assembly instructions

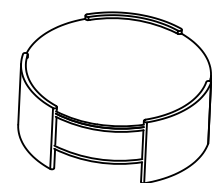

## CT8203 Installation

The number of people needed for installation: 2

- ① Please read the manual carefully before installing this product. And strictly follow the installation process
- ② Please take good care of this manual for your next installation
- ③ Note: Before installation, screw all the screws to 1/2 of the length of the installation. After all screws are half screwed in, tighten them all together.

### 1. Install hardware on the board

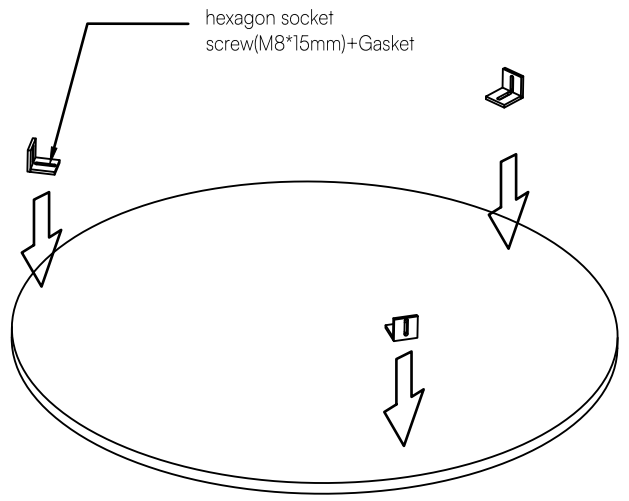

### 2. Install the side panel

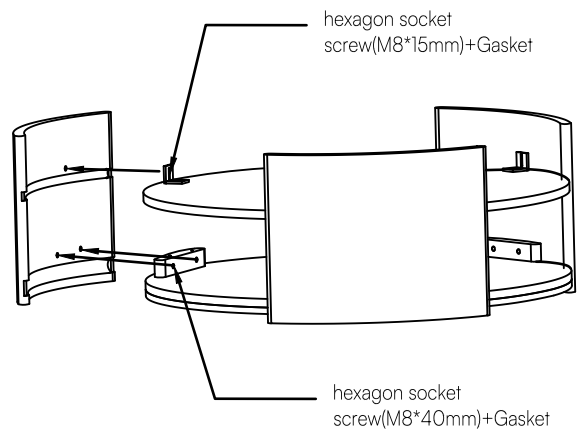

### 3. Installation completed

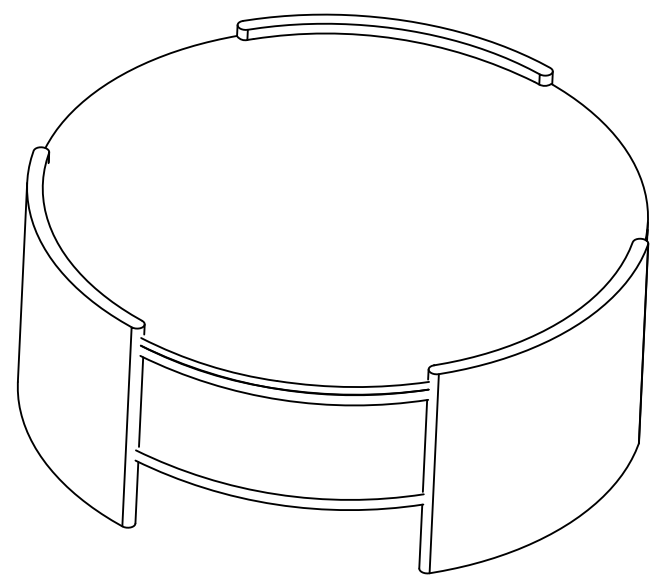

Parts list		On a red ribbon are furniture installation accessories		
Serial number	Shape	Name	Quantity required for installation	Spare quantity
A		hexagon socket screw(M8*40mm)	6	1
B		hexagon socket screw(M8*15mm)	6	1
C		Gasket	12	1
D		Wrench	1	0
E		Connecting piece	3	0
F				
G				